

UPUTE ZA UPORABU

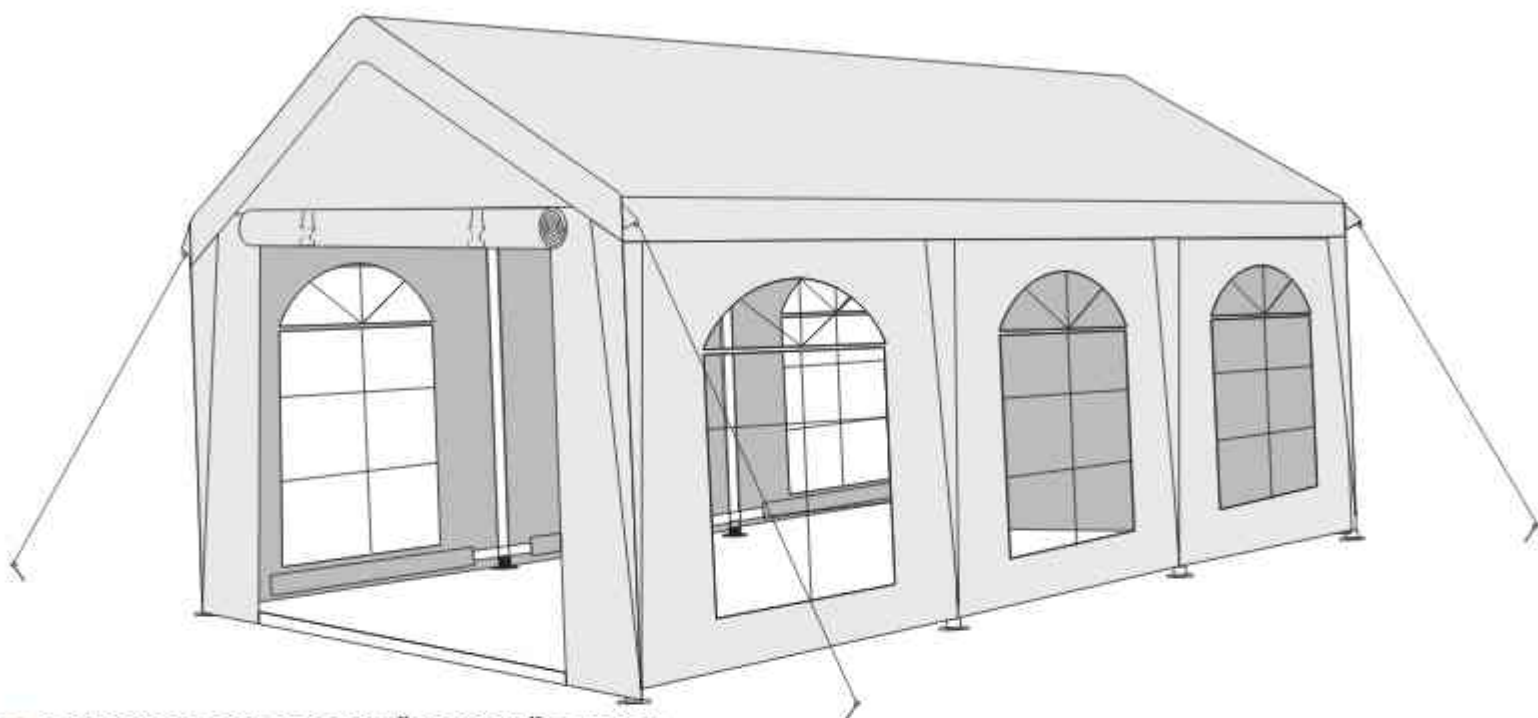

PREPORUKE ZA MONTAŽU I ODRŽAVANJE

Montaža u timu: S obzirom na dimenzije 4x6 m i broj komponenti (npr. 34 komada vijaka M6*50 i 62 komada elastičnih petlji), preporučujemo da montažu obavljaju najmanje 2 do 3 odrasle osobe.

Kontrola spojeva: Tijekom montaže i redovito tijekom uporabe provjeravajte zategnutost svih vijčanih spojeva (L, O, R) i stabilnost spojnice (D, E, H, J).















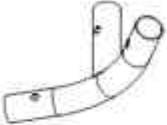



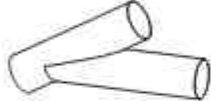

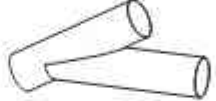
Skladištenje: Prije skladištenja provjerite jesu li sva platna (T, U, V) i metalni dijelovi (A, B, C) potpuno suhi i čisti. Skladištenje u vlažnom stanju može uzrokovati nastanak plijesni na platnima ili koroziju materijala.

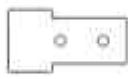
PРАВNA IZJAVA O ODGOVORNOSTI

Ograničenje odgovornosti: Proizvođač niti prodavač ne snose odgovornost za materijalnu štetu, ozljede osoba ili gubitke uzrokovane nepravilnom montažom, zanemarivanjem održavanja ili nepridržavanjem sigurnosnih uputa navedenih u ovom priručniku.

Viša sila: Jamstvo ne pokriva oštećenja uzrokovana višom silom (ekstremno vrijeme, poplave, oluje). U takvim uvjetima korisnik je dužan šator na vrijeme osigurati ili demontirati.

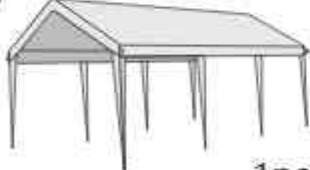
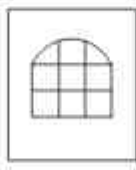
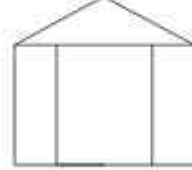
Svrha uporabe: Korištenje šatora u svrhe koje nisu predviđene (npr. kao skladište, garaža za vozila ili trajni zaklon) je na vlastiti rizik korisnika i dovodi do gubitka prava na reklamaciju.

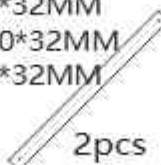
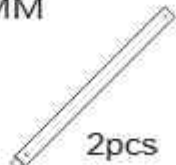
<p>A 1873*38MM</p>  <p>8pcs</p>	<p>A1 (4x6M) 250*38MM (5x6M) 760*38MM (6x6M) 1270*38MM</p>  <p>8pcs</p>	<p>B 1873*38MM</p>  <p>9pcs</p>	<p>C 1920*38MM</p>  <p>8pcs</p>
<p>D</p>  <p>6pcs</p>	<p>E</p>  <p>6pcs</p>	<p>F (4x6M) 1066*38MM (5x6M) 1066*38MM (6x6M) 1920*38MM</p>  <p>4pcs</p>	<p>G 1920*32MM</p>  <p>12pcs</p>
<p>H</p>  <p>8pcs</p>	<p>I 880*38MM</p>  <p>4pcs</p>	<p>J</p>  <p>8pcs</p>	<p>K</p>  <p>8pcs</p>
<p>L</p>  <p>12pcs</p>	<p>M</p>  <p>16pcs</p>	<p>N</p>  <p>16pcs</p>	<p>O</p>  <p>M6*50 34pcs</p>
<p>P</p>  <p>28pcs</p>	<p>Q</p>  <p>4pcs</p>	<p>R</p>  <p>24pcs</p>	<p>S</p>  <p>2pcs</p>
<p>T</p>  <p>1pcs</p>	<p>U</p>  <p>6pcs</p>	<p>V</p>  <p>2pcs</p>	<p>W</p>  <p>62pcs</p>
<p>X 1920*32MM</p>  <p>4pcs</p>	<p>Y 330*32MM (4x6M) 330*32MM (5x6M) 1330*32MM (6x6M) 330*32MM</p>  <p>2pcs</p>	<p>Y1 (6x6M) 1920*32MM</p>  <p>2pcs</p>	

STEP 1



(A) X2



(A1) X2



(D) X1

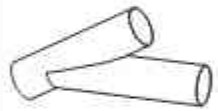

(H) X2



(F) X2

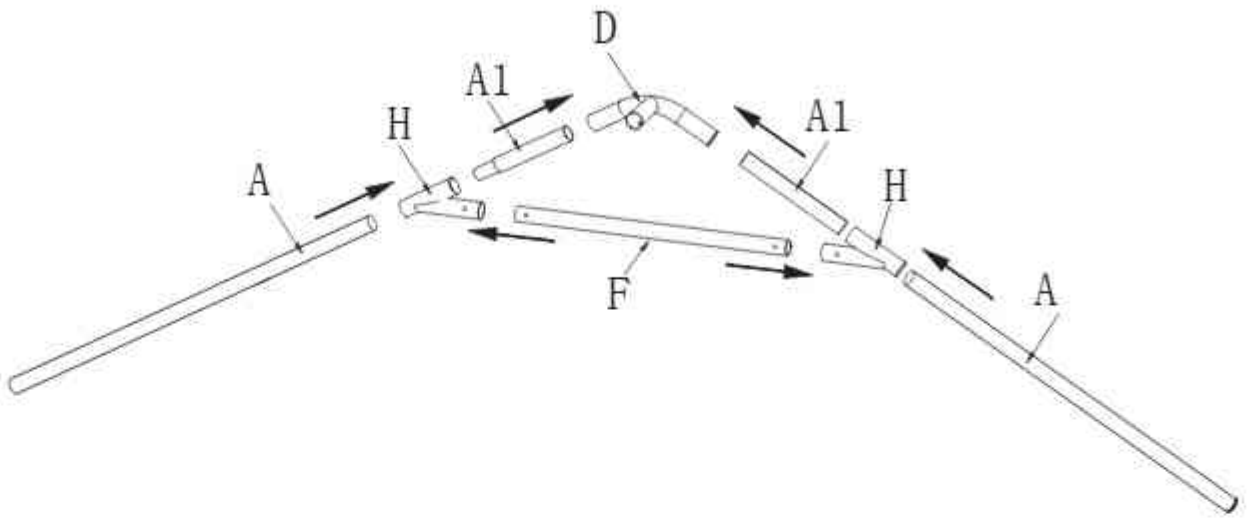

STEP 2



(D) X2

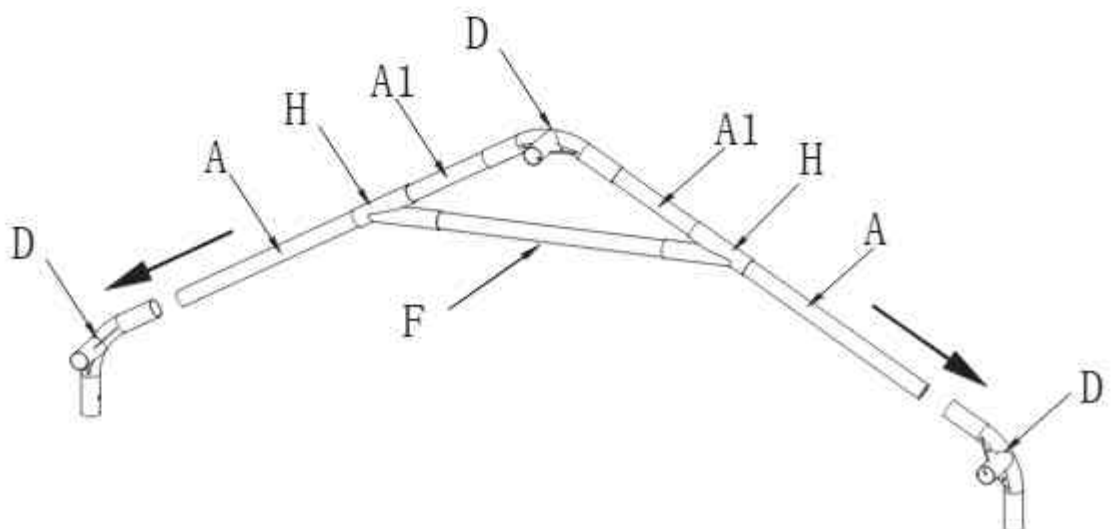

STEP 3

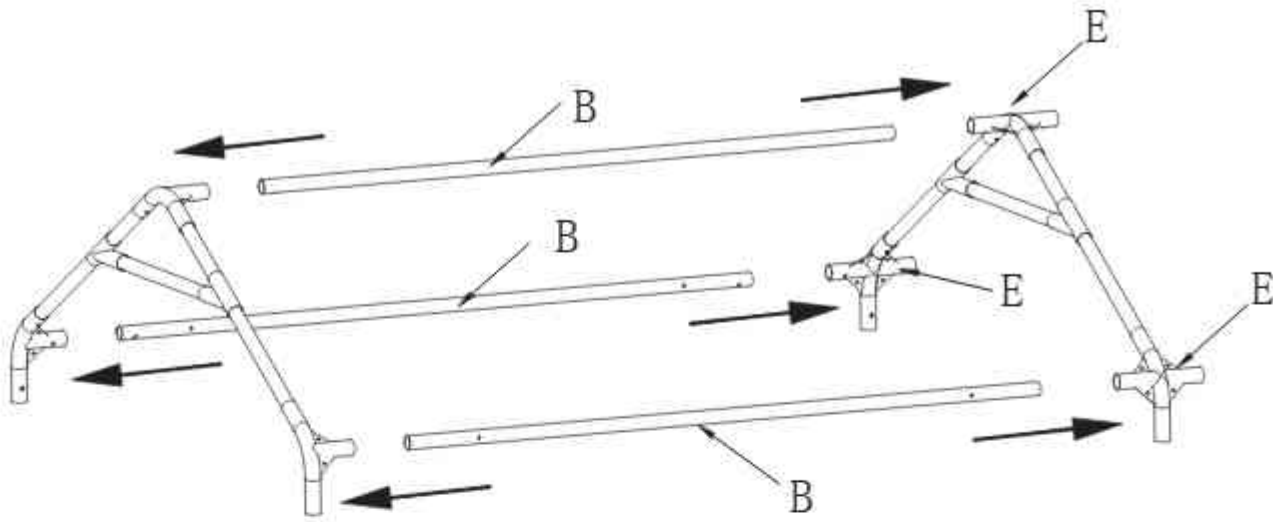

(B) X3



(E) X3

STEP 4

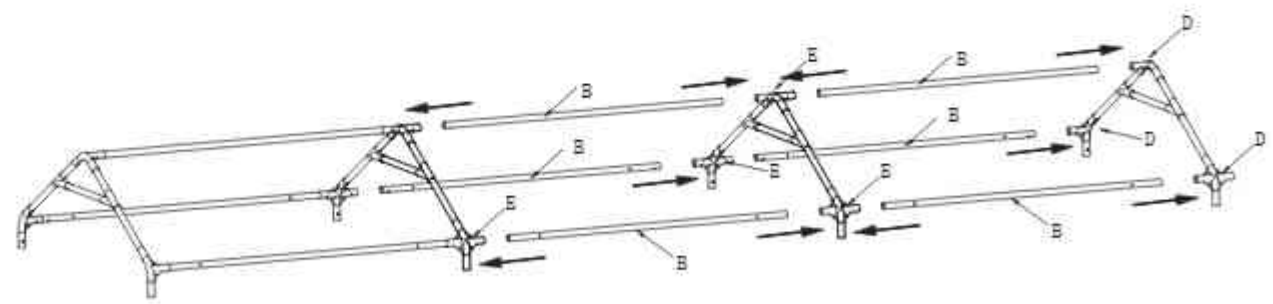

X1

X1

(B) X6

STEP 5

(G) X6

(I) X16

(M) X8

(N) X8

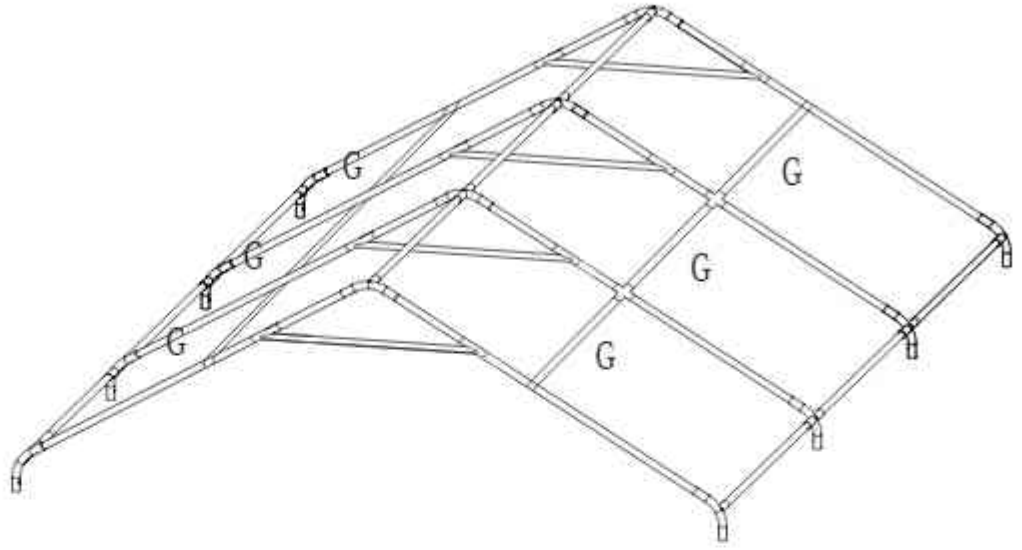

STEP 6

(T) X1

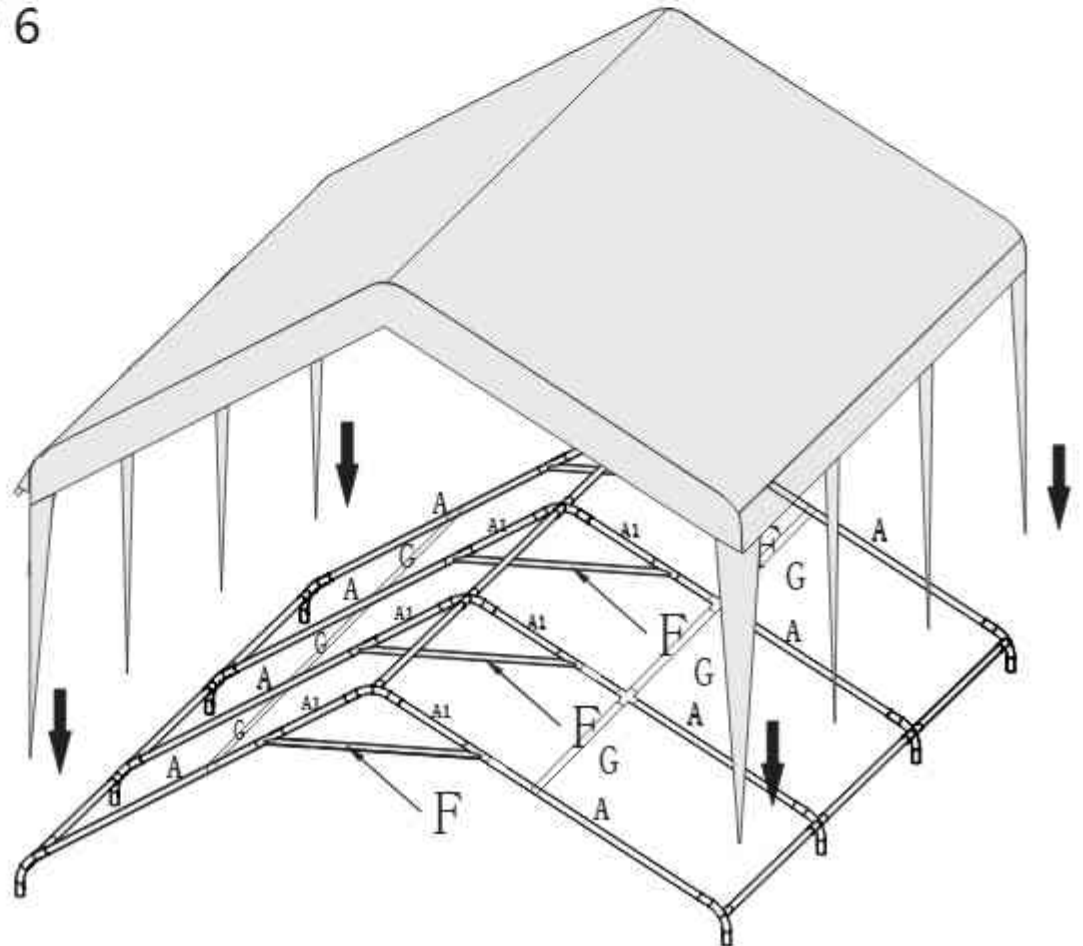

STEP 7



(C) X1



(L) X1



(K) X1

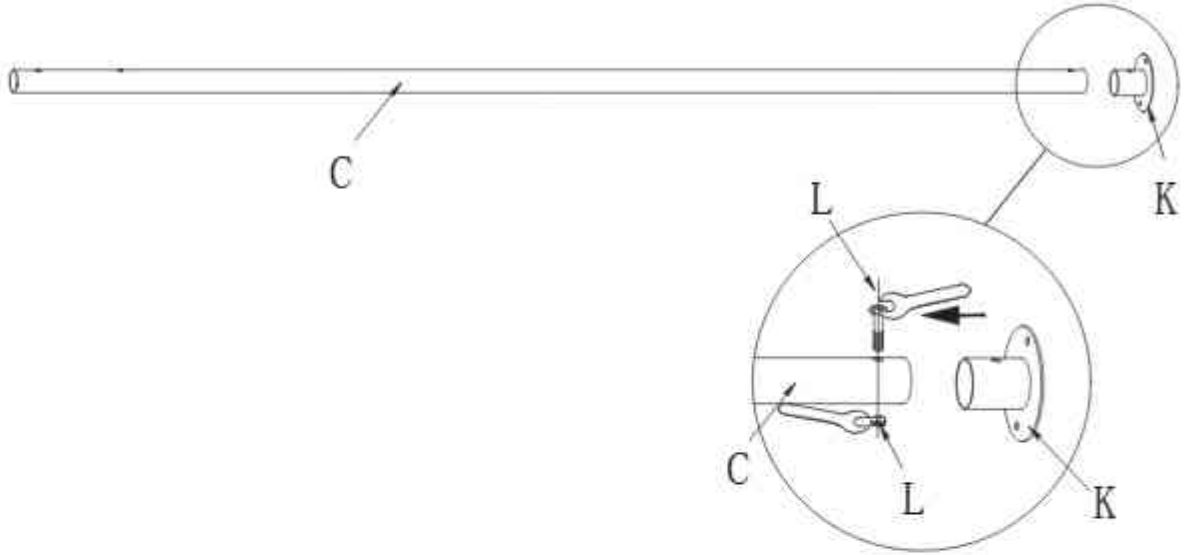

STEP 8



(C) X8



(J) X8



(I) X4

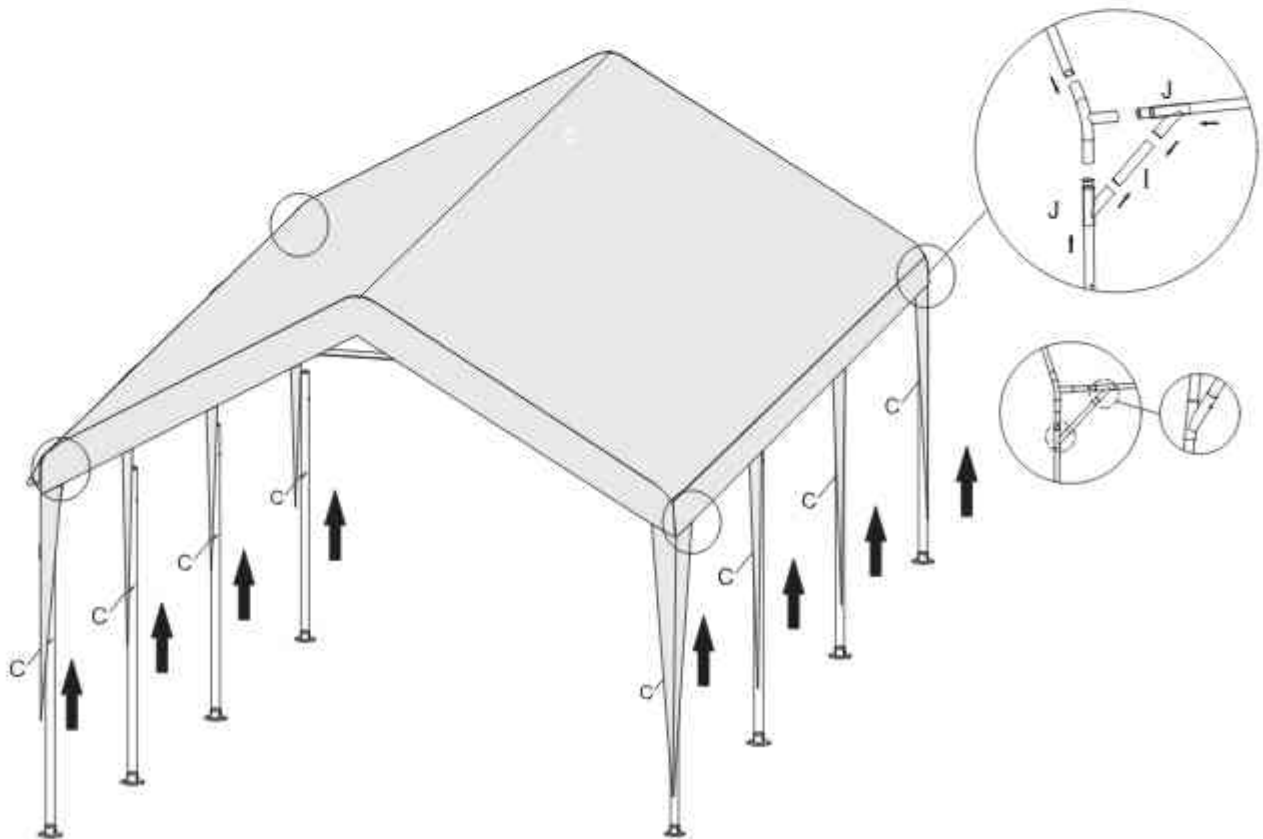



STEP 9

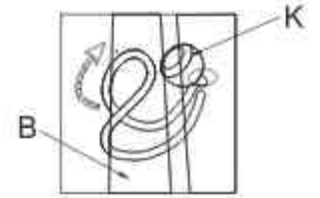

U X6

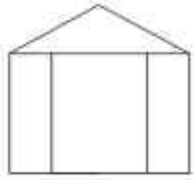
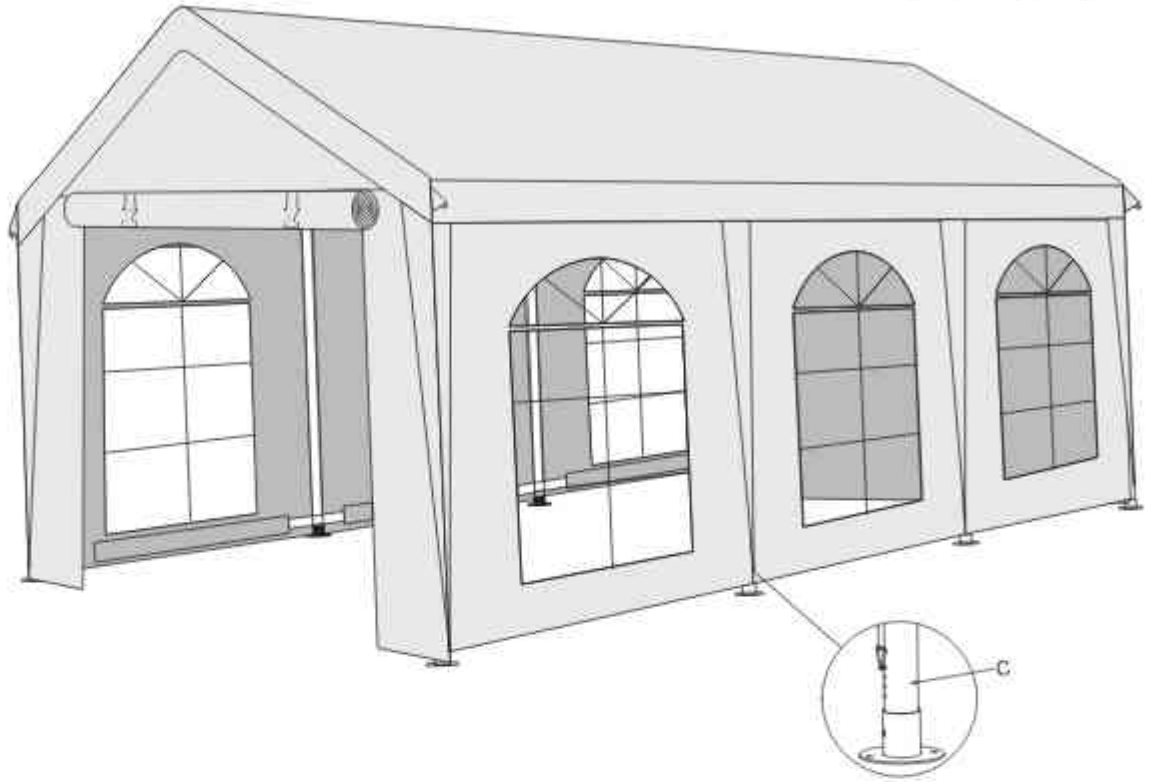

V X2



W X62

STEP 10



X X2

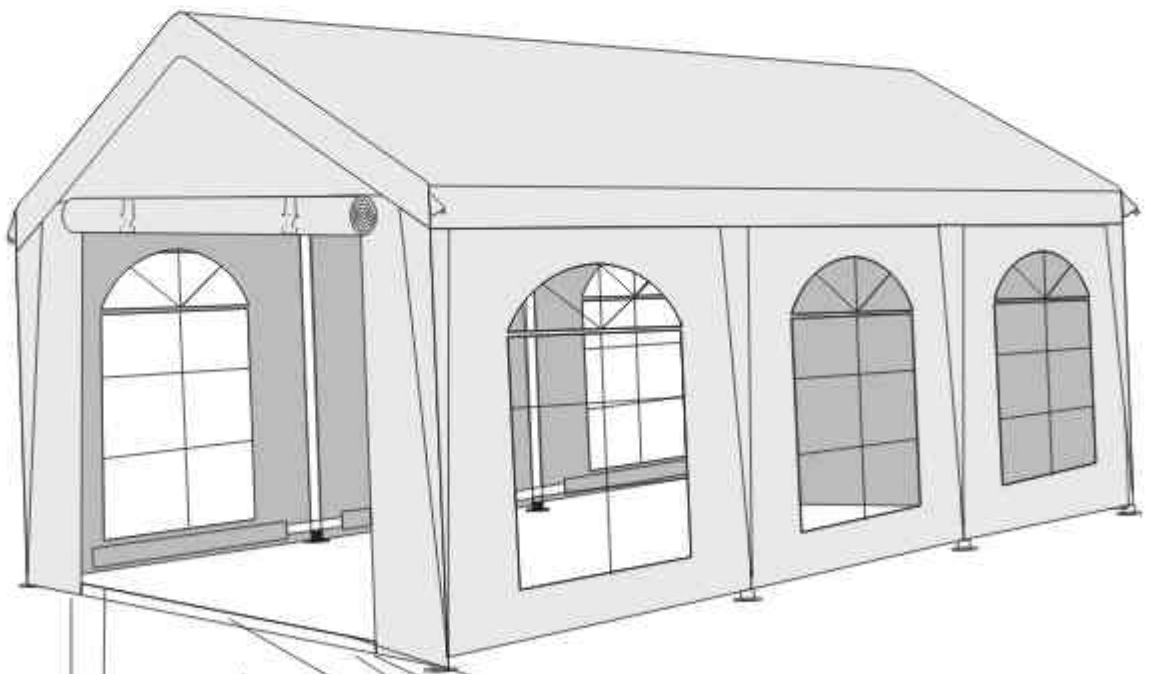

Y X1

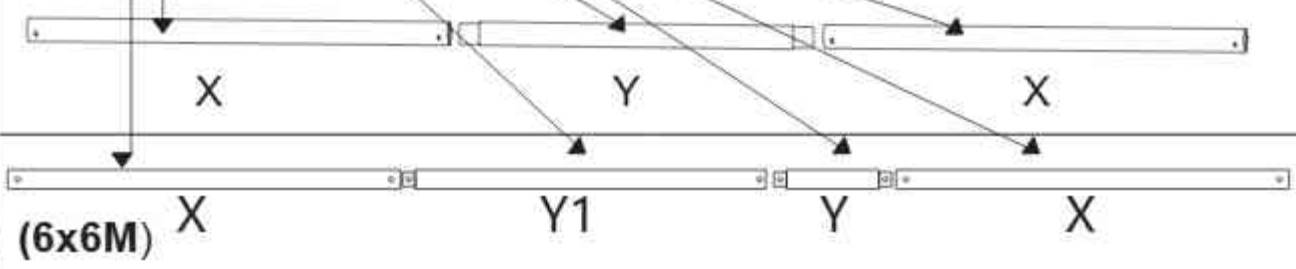

Y1 X1 (6x6M)

(6x6M) X

Y1

Y

X

STEP 11



G X6



M6*50

O X16



M X8



N X8

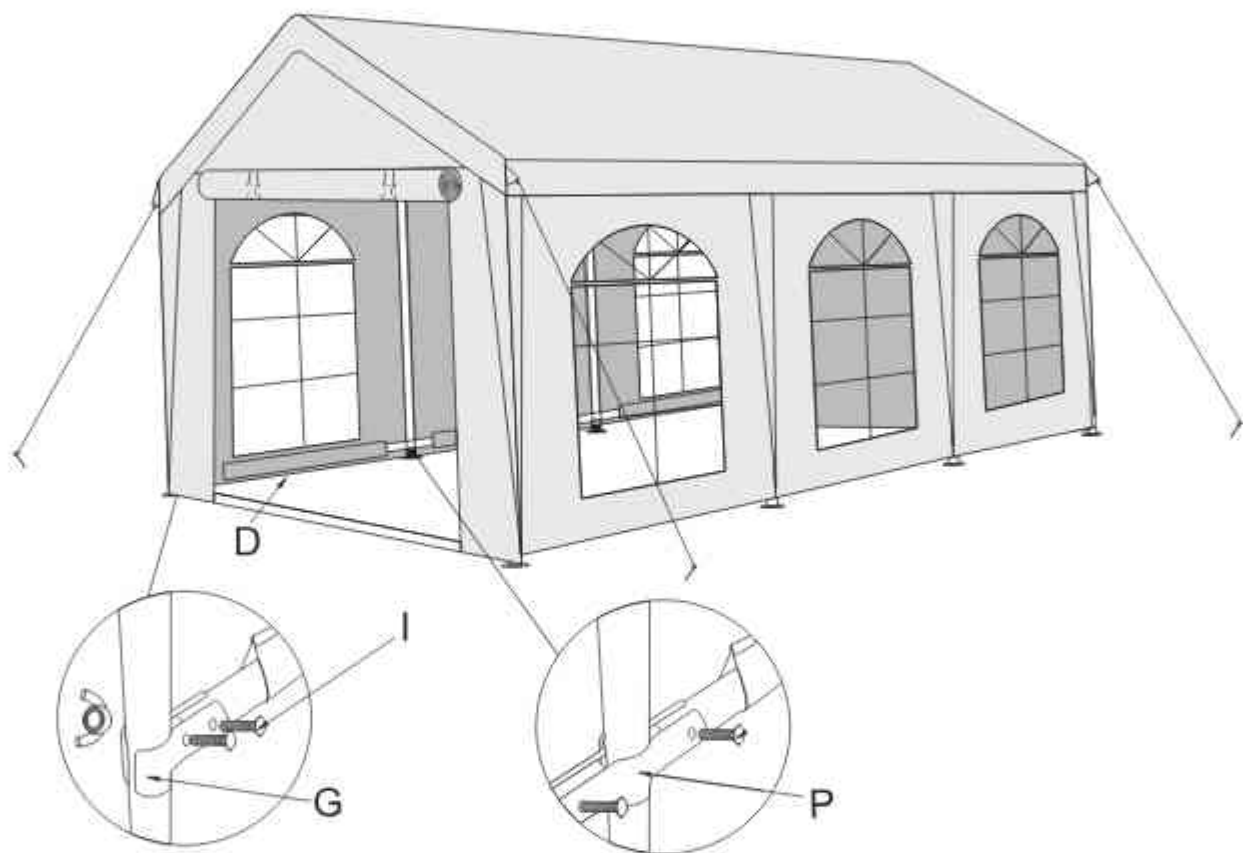

SIGURNOSNO UPOZORENJE *Kratkotrajna uporaba:*

Ovaj šator za zabave dizajniran je isključivo kao privremeni zaklon za kratkotrajna društvena događanja. Nije namijenjen za trajnu upotrebu niti kao dugoročno rješenje za natkrivanje. Obavezno sidrenje: Šator mora u svim okolnostima biti pravilno pričvršćen za tlo pomoću isporučениh klinova (P), užadi (Q) i stopica (K). Nikada ne ostavljajte slobodnostojeći šator bez nadzora. Vremenski uvjeti: U slučaju prognoze nepovoljnog vremena, poput jakog vjetrova, oluje, tuče ili gustog snijega, šator se mora odmah demontirati. Konstrukcija nije dimenzionirana za izdržavanje ekstremnih opterećenja vjetrovom ili snijegom. Zaštita od požara: Unutar šatora ili u njegovoj neposrednoj blizini ne koristite otvoreni plamen, roštilje, grijalice ili druge izvore topline. Postoji rizik od oštećenja cerade (T, U, V) ili nastanka požara. Nakupljanje vode i snijega: Redovito provjeravajte krovnu ceradu (T) kako biste spriječili nakupljanje kišnice ili snijega. Prekomjerna težina može uzrokovati deformaciju metalnih šipki (A, B, C) ili urušavanje konstrukcije.

DETALJAN POSTUPAK MONTAŽE (TEHNIČKA LOGIKA)

Prilikom montaže slijedite numerirane korake u slikovnim uputama: Priprema krovnog okvira (Korak 1 – 4): Prvo sastavite gornji dio konstrukcije (krovište). Koristite središnje spojnice (D, H) i šipke (A, A1, F). Postupno dodajte uzdužne šipke (B) pomoću spojnice (E). Ojačanje krova (Korak 5): Instalirajte krovna ojačanja (G). Ove šipke su ključne za stabilnost cerade i odvodnju vode. Postavljanje krovne cerade (Korak 6): Krovnu ceradu (T) navucite na konstrukciju prije nego što šator podignete na noge. To je sigurnije i jednostavnije. Podizanje na noge (Korak 7 – 8): Postupno umetnite nožne šipke (C) u spojnice. Na donji dio svake noge stavite stopicu (K). Instalacija zidova i donjeg okvira (Korak 9 – 10): Pomoću elastičnih petlji (W) pričvrstite bočne zidove s prozorima (U) i ulazne dijelove (V). Na kraju spojite donje šipke (X, Y) za maksimalnu krutost konstrukcije. Završno osiguranje (Korak 11): Provjerite jesu li svi vijci (O, R) zategnuti i je li šator čvrsto usidren klinovima (P) u tlo.

DODATNE PREPORUKE ZA KORISNIKA

Smjer vjetra: Ako šator postavljate na laganom vjetru, ulaz bi trebao biti orijentiran suprotno od smjera vjetra kako bi se spriječio efekt "padobrana".

Zaštita tekstila: Prilikom zatezanja elastičnih petlji (W) ne primjenjujte prekomjernu silu kako ne biste istrgnuli ušice iz cerade.

Jamstvo na koroziju: Iako su šipke lakirane, u slučaju ogrebotina tijekom montaže preporučujemo da mjesto tretirate antikorozivnim sprejem, budući da se radi o čeličnoj konstrukciji.





 **IDENTIFIKACIJA UVOZNIKA** Uvoznik i vlasnik marke BRIMO: Hana Godušová Adresa: Lermontovová 911/3, Bratislava, Slovačka

SPAJANJE DVA ŠATORA - za duljinu 12m i više (PRODUŽETAK)

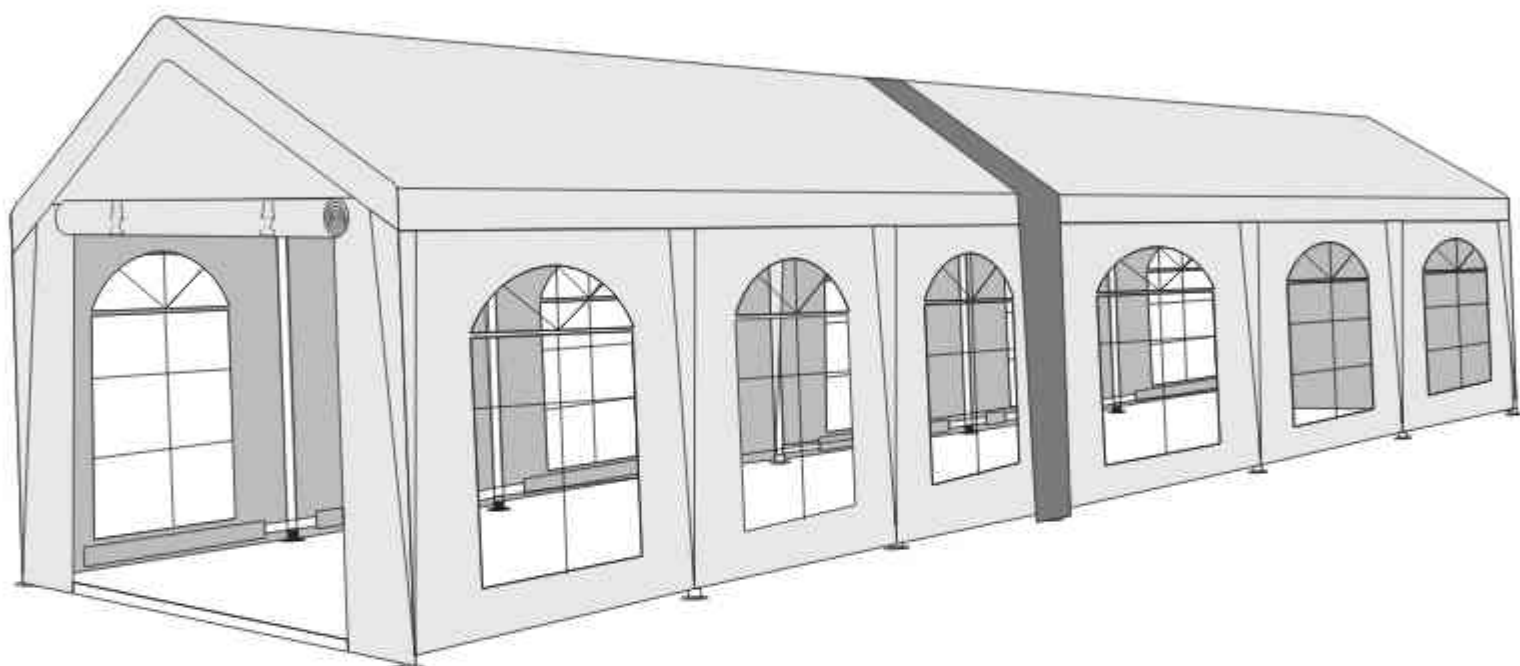
☑ Pri kupnji šatora duljine 12 m i više, ovaj dodatak je automatski uključen u cijenu.

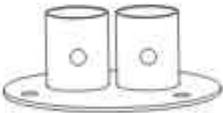
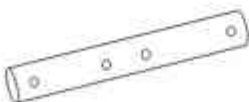
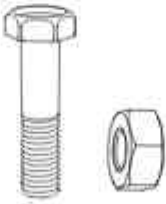
Za šatore 4x6 m, 5x6 m, 6x6 m ovo je dodatak uz nadoplatu.



A  2PCS	B  2PCS	C  4PCS	D  1PCS
E  2PCS	F  4PCS	G S 4PCS	

STEP 1

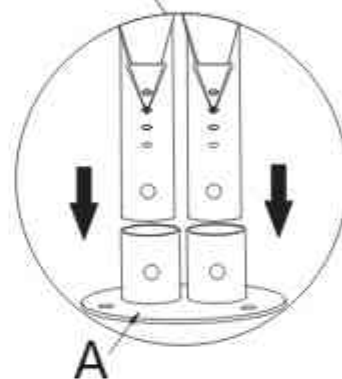
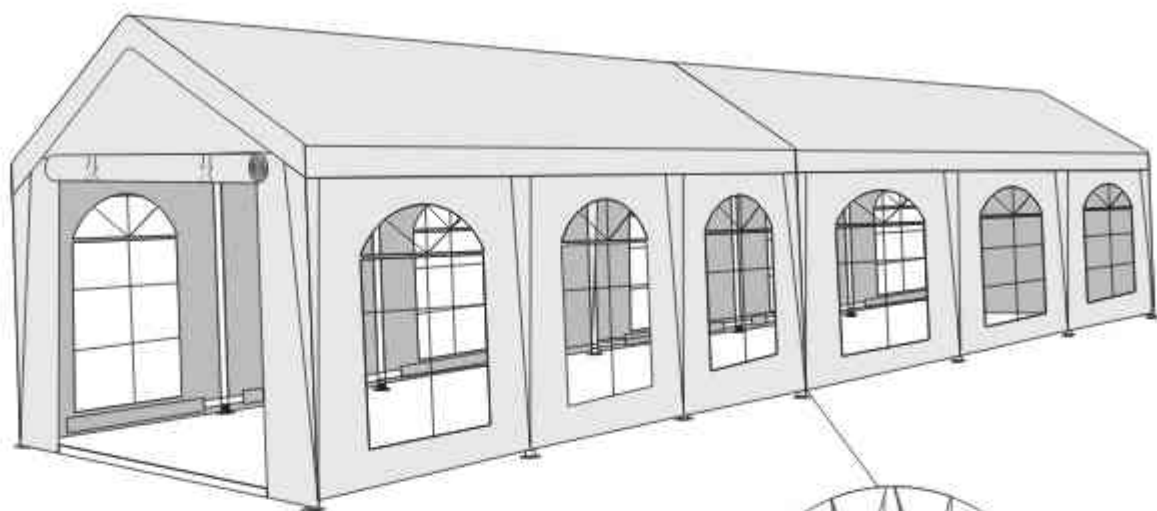
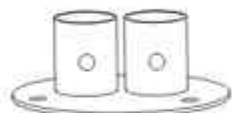

(A) X2

STEP 2

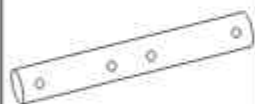

(B) X2



(C) X4



(E) X2

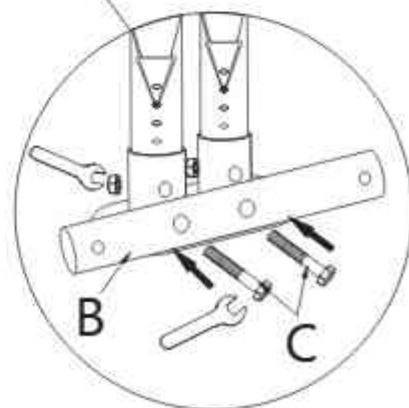
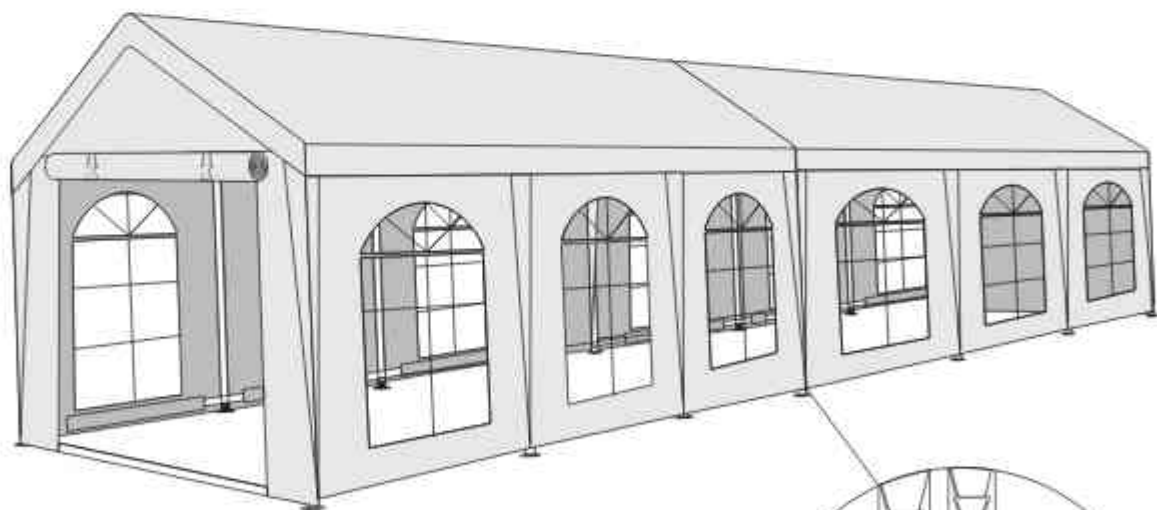

STEP 3



Ⓓ X1

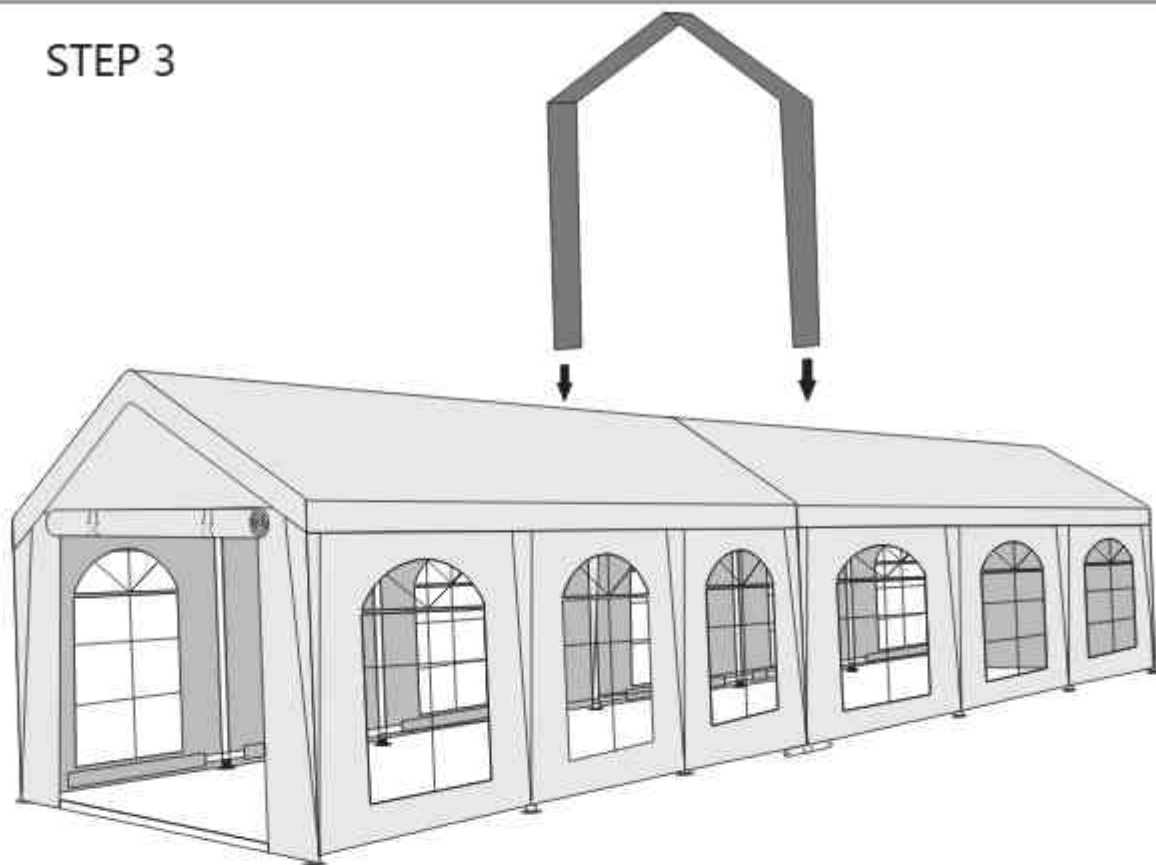

STEP 4



Ⓕ X4

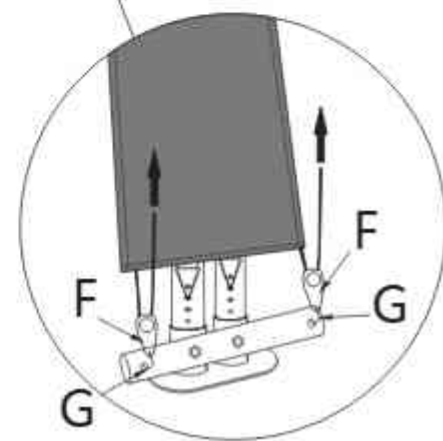
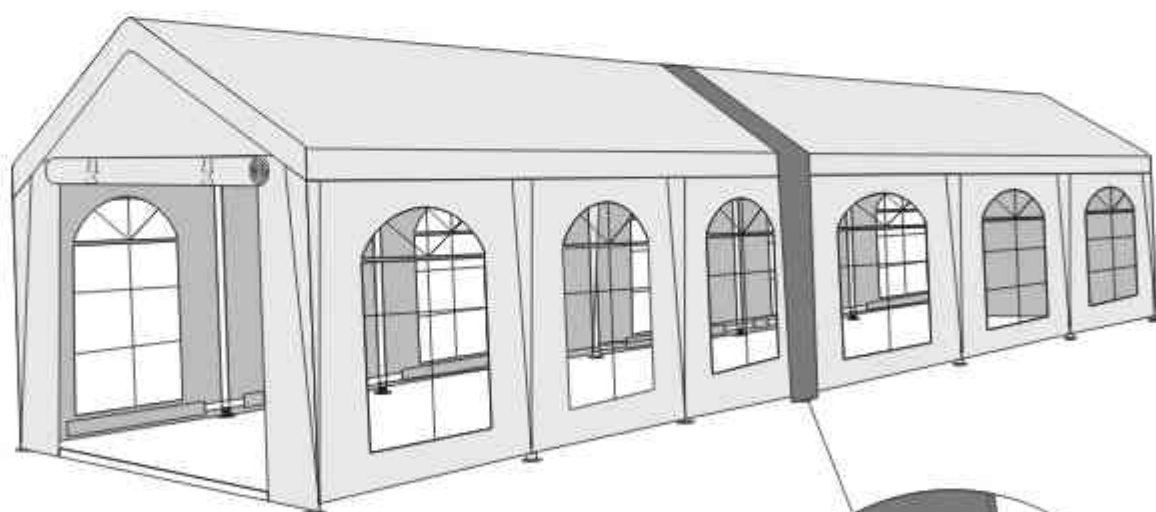

S

Ⓖ X4